

WWW.CASTLE.UK.COM

Tel: 01480 452561 Fax: 01480 413403

CASTLE
Avon Series
LOUDSPEAKER RANGE



IAG

IAG House 13/14 Glebe Road Huntingdon Cambridgeshire PE29 7DL UK
CODE: CH13-MNL001a

INSTRUCTION MANUAL



User Cautions

Now you have opened the carton, please read the following notes carefully. They will help you to install your loudspeakers correctly and safely.

- Do not connect loudspeaker terminals to the mains supply.
- Do not subject your loudspeaker to excessive cold, heat or sunlight.
- Ensure that your loudspeakers are correctly wired and are in phase.
- **WARNING:** To reduce the risks of fire or electric shocks, do not expose this product to rain or moisture.
- The product must not be exposed to dripping or splashing liquids and no object filled with any liquid, such as a vase of flowers, be placed on the product.
- Do not place heavy objects on top of loudspeaker cabinets.
- No naked flame sources – such as candles – must be placed on the product.
- Do not block any ventilation openings in the loudspeaker; doing so may cause irreparable damage to them.
- Be careful to protect the drive units from children and pet, if you play your loudspeakers with the grilles removed.
- Do not attempt to dismantle the loudspeaker. There are no user serviceable parts inside and you will invalidate the warranty of the product by doing so.
- Do not use makeshift stands. Always fit a manufacturer's approved stand using the instructions and fixing provided. Your dealer will advise you further on this.
- **SWITCH OFF** the amplifier and all sources before making connections to your sound system.
- When you switch on the system or change sources, set the volume control to minimum and gradually turn on the volume level.
- The position of your volume control is NOT a reliable guide as to the maximum capabilities of your system. Playing the system with extreme settings of volume and tone controls may damage the amplifier and loudspeakers.

Specifications

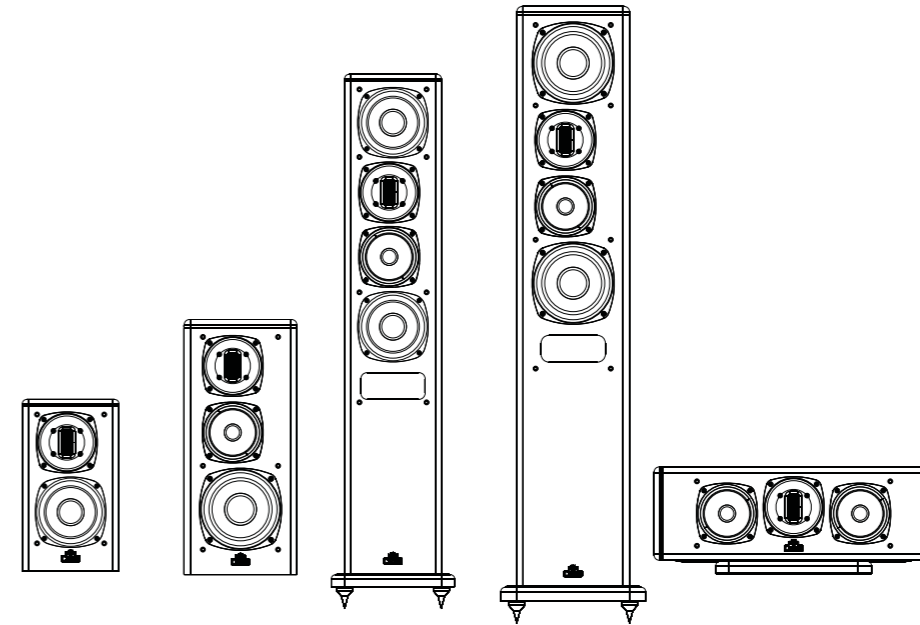

Avon Series

Parameter	Avon 1	Avon 2	Avon 4	Avon 5	Avon C
Description	2-way	3-way	3-way	3-way	3-way
Format	Stand Mount	Stand Mount	Floorstanding	Floorstanding	Centre Speaker
Enclosure type	SDEL - Single Drive	SDEL - Single Drive	TDTL - Twin Drive	TDTL - Twin Drive	TDEL - Twin Drive
Bass Driver	Extended Line 130mm	Extended Line 150mm	Transmission Line 130mm	Transmission Line 2 x 150mm	Extended Line 2 x 150mm
Midrange Driver	–	115mm	115mm	115mm	2 x 115mm
Tweeter	12 x 45 mm True Ribbon	12 x 45 mm True Ribbon	12 x 45 mm True Ribbon	12 x 45 mm True Ribbon	12 x 45 mm True Ribbon
Recommended Amplifier Power	25 - 100W	25 - 100W	25 - 100W	25 - 100W	25 - 100W
Nominal Impedance	8 Ohms Compatible	8 Ohms Compatible	8 Ohms Compatible	8 Ohms Compatible	8 Ohms Compatible
Sensitivity (1W@1M)	87 dB	88 dB	89 dB	89 dB	90 dB
Nominal Frequency Range	60Hz - 20kHz	50Hz - 20kHz	45Hz - 20kHz	35Hz - 20kHz	65Hz - 20kHz
Bass Extension (-6dB)	55Hz	45Hz	40Hz	30Hz	60Hz
Crossover Frequency	2.5 kHz	320Hz & 3.2 kHz	320Hz & 3.6kHz	300Hz & 3.6kHz	300Hz & 3.8kHz
Dimensions (HxWxD) (mm)	320 x 180 x 260	475 x 210 x 310	930 x 180 x 310	1080 x 210 x 365	175 x 520 x 320
Height on plinth and spikes	–	–	955	1110	200
Net Weight	5.8 kg (12.8 lbs)	10.5 kg (23 lbs)	17.6 kg (38.7 lbs)	24 kg (52.8 lbs)	14 kg (30.8 lbs)
Carton Size (mm)	520 x 350 x 440	590 x 410 x 605	1130 x 420 x 310	1290 x 480 x 340	620 x 400 x 310
Gross Weight	13.2 kg (29 lbs)	23 kg (50.6 lbs)	19.2 kg (42.2 lbs)	26.2 kg (57.6 lbs)	15.2 kg (33.4 lbs)
Finishes	Specially selected Deep Figured Veneers sealed with 'natural feeling' semi matt clear lacquer				



Produced after 13th August 2005.

Waste electrical products should not be disposed of with household waste. Please recycle where facilities exist.

Check with your Local Authority or retailer for recycling advice.



Final Thoughts

Looking After Your Loudspeaker

- o Your Castle Loudspeakers use a specially hardwearing sealed finish. They should not be waxed or treated with spray polishes which will smear and dim their lustrous finish. Occasionally polish them with a dry or barely moist cloth to remove dust and finger marks, etc.
- o Occasionally, remove the loudspeaker grilles and brush them gently with a soft brush before replacing them carefully.
- o Never stand objects on your loudspeakers. In particular do not stand flowers etc. on them - they are not jardinières!
- o Avoid getting any liquid behind the grille. If you accidentally spill liquid on your loudspeakers, take them to your dealer for attention before using them again.
- o Do not open the speakers; there are no user serviceable parts inside. Never touch the drive units either with an object or your hands.

Quality Assurance

Your Castle loudspeakers have been constructed to the highest standards. From the top grade furniture construction and finish to the carefully designed and selected acoustic components, the Castle range is a testament to fine design, fine engineering and fine craftsmanship. Our speakers are built to provide a lifetime of pleasure to the eye, the ears and through the music they play, the soul. We hope you will derive many years of good service from our products.

Servicing and Warranty

Servicing of Castle products should only be carried out by authorised service agents. If service is required the equipment should be returned, securely packaged, preferably using original packaging, to your dealer.

In the UK equipment may be returned to the IAG Service Centre. Always telephone before returning any equipment. A note should be enclosed giving your name, address, telephone number, and a brief description of the reason for return.

The warranty of this product is not transferable. If you require service outside the Warranty period, do not hesitate to contact your dealer.

Service Addresses

For technical support, servicing, product queries or information please contact either your local retailer or the main offices below.

UK

IAG Service Dept.
IAG House
13/14 Glebe Road
Huntingdon Cambridgeshire
PE29 7DL
England
Tel:+44 (0)01480 452561
Fax: +44 (0)01480 413403

Asia

IAG Sales and Service Centre
Jiuwei, XixiangTown,
Shenzhen,
China 518102
Tel: +86-755-27484491
Fax: +86-755-29651484

Introduction - A Tradition Renewed



The Avon series is the new TL System range from Castle. Retaining the hand built, craftsman finished real wood veneers for which Castle is famous, Avon loudspeakers feature the latest technology in Transmission Line systems.

For Avon series Castle engineers redefined the Transmission Line concept, solving age old problems using advanced computer modelling to yield floorstanding loudspeakers that provide the highest possible bass articulation and extension.

Building on the Castle innovative quarter wave principle, the Avon floorstanding loudspeakers use a new TDTL (Twin Drive Transmission Line) driver and cabinet combination. Here twin, spaced bass units drive the Transmission Line in optimal fashion, improving efficiency and bandwidth while delivering the extended, powerful bass for which the Transmission Line is famous.

In the stand mount Avon loudspeakers Castle engineers developed the SDEL (Single Drive Extended Line) system, utilising Transmission Line principles to provide powerful bass extension within a compact cabinet size.

Of course these innovations in bass performance need to be matched by equally pure and precise midrange and treble presentation. Accordingly Avon series speakers use a precision midrange unit and ribbon tweeter arrangement that provide the utmost clarity and musical detail to perfectly match the advanced bass quality.

We are sure you will enjoy all your music replayed and revealed afresh from the Castle Avon series.

Contents

User Cautions	IFC
Introduction	1
Good Practice Guide	2
Unpacking The Equipment	3
Fitting Spikes	3
Cables and Connectors	4
Crossovers	5
Connecting your Loudspeakers	6
Positioning Stereo Loudspeakers	7
Positioning Castle Avon AV Loudspeakers	8
Setting Up a Home Theatre System	9
Final Tuning Procedures	10
Final Thoughts	12
Quality Assurance	12
Service and Warranty	12
Specifications	13



Foreword

Before connecting and using your loudspeakers, please bear the following points in mind:

- Switch off the amplifier and all sources before making connections to your sound system. When you switch on the system or change sources, set the volume control to minimum and turn up the level gradually.
- The position of your Volume Control is NOT a reliable guide as to the maximum capabilities of your sound system. Playing the system with extreme settings of volume and tone controls may damage the amplifier and loudspeakers.
- Do not connect loudspeaker terminals to the mains supply.
- Ensure that your loudspeakers are correctly wired and are in phase.
- Do not subject your loudspeakers to excessive cold, heat or sunlight.
- If you are shelf mounting your loudspeakers, make sure they are not placed on the same shelf as your source components.
- Do not place heavy objects on top of loudspeaker cabinets. If you play the loudspeakers with the grilles removed be careful to protect the drive units from children and pets.
- Do not use makeshift stands. Always fit a manufacturer's approved stand using the instructions and the fixings provided. Your dealer can advise you further on this.
- Do not attempt to dismantle the loudspeaker. There are no user serviceable parts inside and you will invalidate the warranty.
- Some Front and all Centre loudspeakers are magnetically screened. You should place front loudspeakers at least 0.5m away from TV sets and magnetic storage media.
- When connecting your loudspeakers, do not run cable across areas of open floor where they may be a source of danger. Run them safely, around room boundaries if necessary.

Delay and LFE Settings

The purpose of delay is to enable surround and dialogue information to arrive at the listener's ears at the same time as the Front channels, even when the listening seat is in a non-ideal position.

Rear Delay: If the listening position is equidistant from the Front and Rear speakers, a low delay setting should be set. The closer the listener is to the Rear speakers the higher should be the delay setting used,

Centre Delay: If the Centre speaker is level with (or slightly behind) the Front speakers, set the delay to zero. If the Centre speaker is forward of the Front speakers, increase the delay.

If you hear popping or thumping noises coming from the front loudspeakers or subwoofer, immediately turn the AV Processor's volume level down and then back off the LFE level. This should cure the problem. If it does not, back off the volume level at the subwoofer (if you are using one) until the problem disappears.

Please read the relevant sections of your AV amplifier manual and familiarise yourself with the various issues. If you are unsure, consult your dealer for help.

Expanding the System

Dolby Labs, DTS and THX offer 6.1 and 7.1 formats. Although the precise configuration of these systems will depend on the capabilities of your processor and you should be guided by those instructions, we would make some observations.

For most 6.1 and 7.1 formats, and especially Dolby ES, the listening seat should not be too close to the rear wall. Optimising the time delay so that information from all speakers arrives at the listening seat coherently is critical if the benefits of these systems are to be fully realised.

Dolby Labs Recommended 7.1 Placement

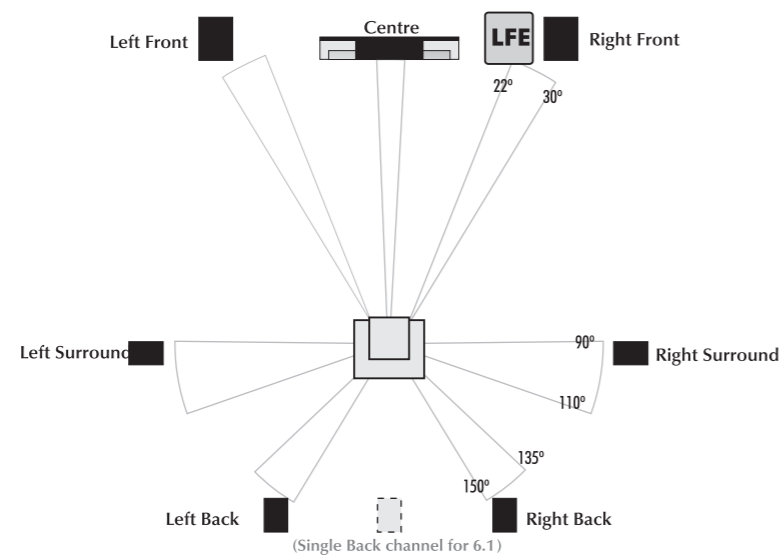

Fine Tuning Procedures

Loudspeaker Phasing: Make sure that all loudspeaker channels are connected in phase. If there is a doubt about the way the loudspeakers are connected, check their phasing by playing a mono source - the sound should appear from a point midway between the front loudspeakers. If this position is indefinite, reverse the connections to one speaker. Correctly connected loudspeakers give a definite centre sound source with fuller bodied tenor and bass registers.

Setting levels: Once the loudspeaker settings have been finalised, put the AV amplifier into its 'Test' mode (see instructions supplied with your processor). Adjust the levels until all channels are reproduced at equal loudness.

Unpacking Your Loudspeakers

- Castle loudspeakers come in many shapes and sizes. Now you have opened the carton, please read this manual.
- If you are unpacking the larger loudspeakers or the Classic Subwoofer, please remember that these units are heavy. We suggest that you have someone to assist you.
- Lift the loudspeaker carefully out of the packing, DONOT try and lift the loudspeaker using the cloth bag.
- Unpack any accessories carefully. The larger loudspeakers will need to be assembled on their plinths and spike kits.
- If there is any sign of damage or if the contents are incomplete, report this to your dealer as soon as possible.
- Retain the packing for future safe transport of the product. If you dispose of the packing, do so with respect to any recycling provisions in your area.
- Stand mounting and AV loudspeakers are ready to be connected after unpacking. The larger loudspeakers will need to be assembled on their plinths and spike kits.

Attaching the Plinth and Spikes to Floorstanding Models

- Make you have plenty of unobstructed working space.
- Place a soft cloth on the floor to protect the loudspeaker.
- Invert the loudspeaker onto the cloth.
- Thread a locknut onto each spike and loosely run it up the thread

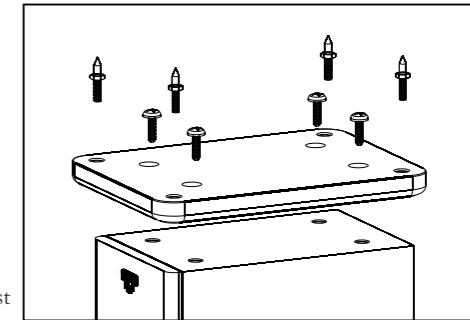

Using the spacers:

Spacers are provided with these floor standing loudspeakers. These must be attached as shown below to tune the lower frequencies correctly.

Attaching Plinth:

- Place the plinth on the loudspeaker. Place a washer over each of the four round head screws. Insert the screws into the threaded holes on the loudspeaker and tighten securely.
- Thread the spikes onto the spike inserts. Tighten them finger tight.
- Invert the loudspeaker. Take care not to damage the floor with the spikes.

Levelling the Loudspeakers

- **When the speaker is upright:** You will probably find that the speaker will wobble with one spike not contacting the floor. Adjust this spike until all four spikes are on the floor. With the aid of a spirit level move each spike in and out until the loudspeaker is level and sitting squarely on all four spikes with no rocking.
- Now tighten each locknut securely against the collar in the plinth to secure the spike
- A spike seat is provided for use on wood or stone floors etc. and should be placed as shown.

*** On most models four self leveling soft rubber feet are included as an alternative to spikes.**

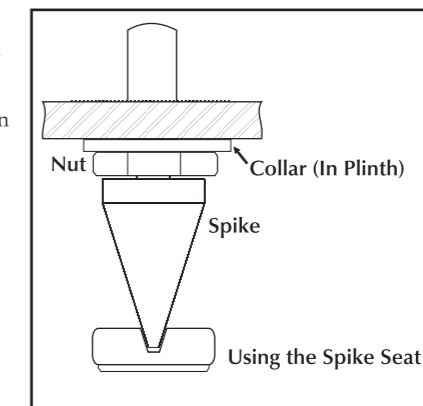

Cables and Connectors

Choosing Loudspeaker Cable

Specialist audio cable usually offers better performance than general purpose 'bell' or 'zip' wire.

Choose a cable of suitable diameter – cable that is too thin will limit the dynamics of the sound and may impair the bass response. Audio cable is polarised, with two cores of different colours, or often a raised rib or coloured tracer in the case of twin cable.

Before you purchase your cable, we suggest that you give careful thought to the positioning of your loudspeakers. This is especially the case if you are bi- or tri-wiring your loudspeakers.

Cable lengths to loudspeaker pairs should be the same for left and right channels in order to equalise the signal transmission. Allow some slack in your speaker cables so you can alter their position of your speakers to optimise the sound.

Preparing Loudspeaker Cable

Split the twin cores to a depth of about 40mm. Carefully strip the insulation from each end, leaving about 10mm of bare wire. If the cable is stranded, lightly twist to gather any loose strands.

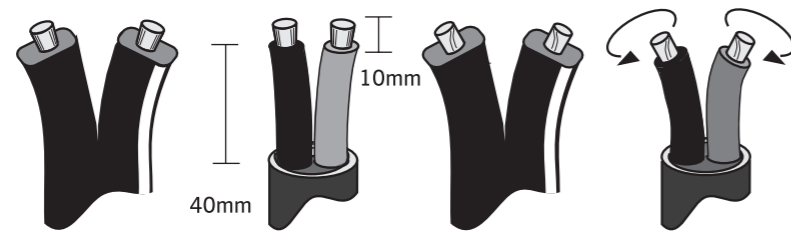

Connecting Screw Terminals

All the Castle loudspeakers use screw terminals.

Safe Connection of Terminals

Unscrew the terminal. Insert the bare end of the cable into the hole in the base of the terminal. Tighten securely.

When connecting terminals make sure you leave no strands of bare wire that can short across to adjacent terminals.

As an alternative to bare wire you can use specialist spade connectors. Your Castle dealer will be pleased to advise you.

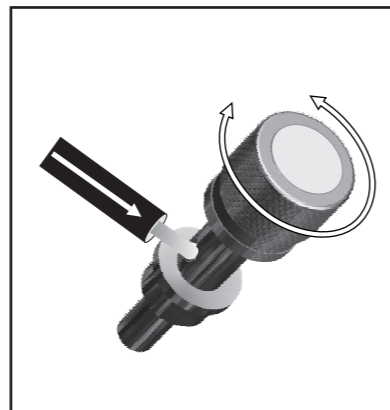

Setting Up a Home Theatre System

Some of this chapter may appear to repeat the content of the Subwoofer pages - the context however is different.

Placement

Front And Effects Channels

The front loudspeakers are placed on either side of the television screen, 2 to 3 metres apart. The speakers should be angled slightly so they are aimed towards the listeners.

We recommend placing the rear effects speakers in a high position, behind the listener's head. If the rear or side walls are a long way from the listening seat, consider stand mounting the loudspeakers. If the centre loudspeaker is very high or low, angle it towards the listener's ear level. The front faces of the centre and surround loudspeakers should also be in line as far as possible.

Subwoofer

As the ear is unable to detect the direction from which deep bass originates, this allows you freedom to position the unit. Varying the distance from the wall alters the bass. Placing the subwoofer across a corner boosts the bass but may impair clarity. The performance of Home Theatre systems can often be enhanced by using a pair of subwoofers.

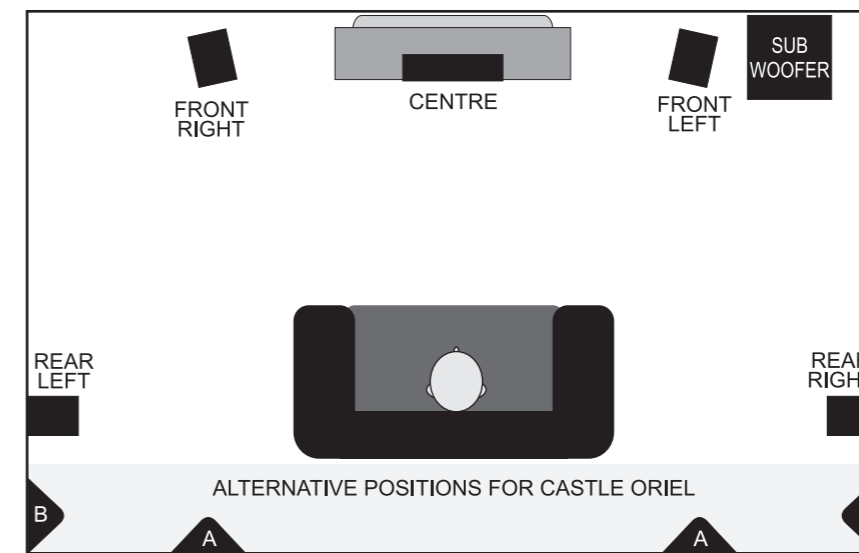

Setting Loudspeaker Sizes

Many digital AV Processors ask you to specify the size of speakers in all channels - usually 'Large' or 'Small'. The Floor standing Castle loudspeakers may be safely set to 'Large'. The other loudspeakers should be set to 'Small'

If you are not using a subwoofer: Set the Front Speakers to 'Large'. Set the 'Subwoofer' option on the processor to 'Off' or 'No'. The Front channels will now receive all the system bass.

If you are using a subwoofer: When set to 'Small' all the system bass will go into the subwoofer. If you choose 'Large' the Front channel bass will be reproduced from the Front speakers.

Once the loudspeaker settings have been finalised, put the AV amplifier into its 'Test' mode (see instructions supplied with your processor). Adjust the level of each channel until all channels are reproduced at equal loudness.

You may need to adjust the subwoofer output level. Avoid setting too high a level or you will swamp the sound with bass and may limit the subwoofer's ability to respond to large bass transients. You should also set a sensible level going into the subwoofer from the AV processor.

Positioning Castle Avon AV Loudspeakers

Front Loudspeakers: The front loudspeakers are placed on either side of the TV monitor, 2 to 3 metres apart. The speakers should be angled slightly so they are aimed towards the listeners.

Rear Surround channels: The reproduced sound should be as room filling as possible. We recommend placing the speakers in a high position, behind the listeners head. If the rear wall is more than 1 metre behind the listening seat, an alternative position is on the side walls. If the walls are a long way from the listening seat, consider stand mounting the loudspeakers.

Centre Channel: Most of the dialogue comes from the centre loudspeaker. Speech should appear to originate from the actors mouths. Operating height is important. Ideally the front and centre channel speakers should be at the same height. The front of the cabinet should be level with the TV screen.

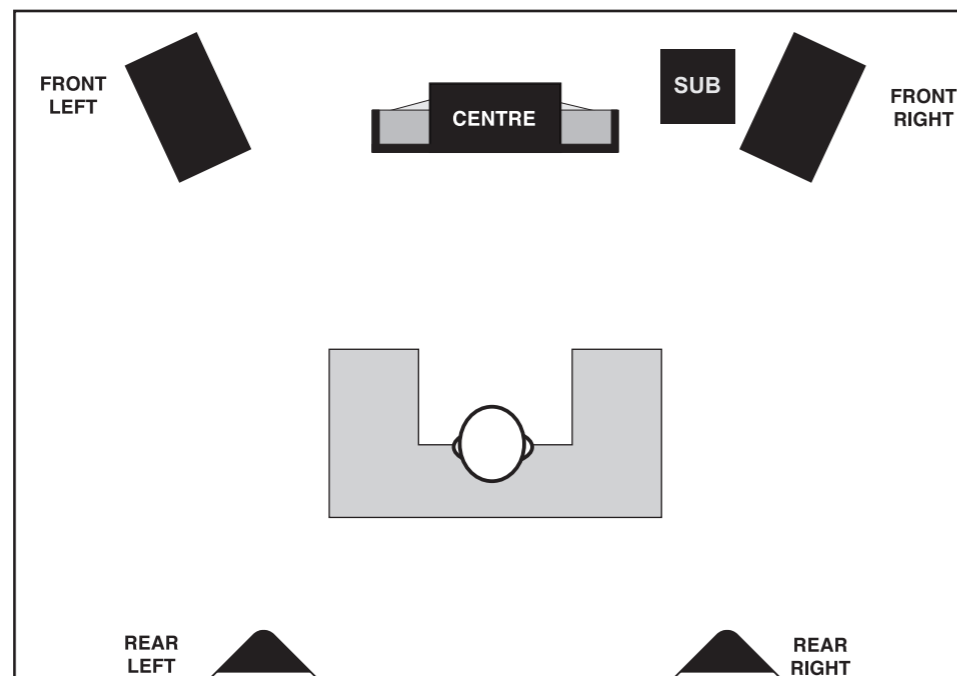

Crossover Networks

The Castle Avon Series use bi-wired terminal panels.

Biwireable Crossovers

A bi-wiring panel has four terminal binding posts. The upper terminals connect to the treble units, the lower pair to the bass unit.

As supplied the treble and bass terminal pairs are connected via removeable straps. This arrangement facilitates standard single wiring, and advanced bi-wiring which offers significant performance advantages. Follow the drawings carefully to see the correct orientation of the loudspeaker terminals.

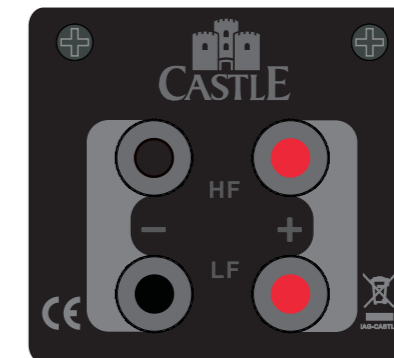

As supplied

Why Bi-Wire?

Bi-wiring involves the use of two separate cables between the amplifier and the loudspeakers. One pair connects to the treble unit the other to the bass driver.

Using separate cables for treble and bass units in a Bi-Wiring configuration reduces intermodulation effects and improves headroom and clarity. To bi-wire, you will need to install two lengths of twin core cable between the amplifier and each loudspeaker.

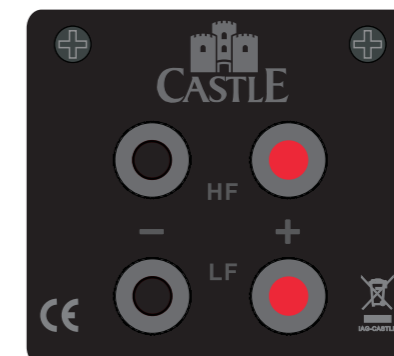

In bi-wiring mode

Bi-amplifying

The bi-wiring principle can be further extended by bi-amplifying (bi-amping). To bi-amp you will need two amplifiers per loudspeaker. One amplifier is connected to the treble terminals and the other to the bass terminals of the crossover panel. Bi-amping offers the greatest clarity. Because each amplifier is working over a narrow range, intermodulation distortion is virtually eliminated and acoustic performance optimised.

The amplifiers in the treble and bass sections of a bi-amped loudspeaker need not be identical but they must exhibit the same phase characteristics. If you wish to bi-amp your loudspeakers we suggest you consult your Castle dealer if you are in any doubt.

Connecting Your Loudspeakers

Standard Loudspeaker Wiring

Choose a suitable length of twin core speaker cable for each channel, and prepare the ends. Unscrew each terminal a few turns.

Connect the red, positive (+) terminal of the Left loudspeaker to the corresponding red, positive (+) amplifier terminal. Connect the black, negative (-) terminals similarly. Tighten the terminals securely. Repeat this procedure for the Right Channel.

If you are standard wiring a bi-wiring panel, make sure that the binding straps are securely in place.

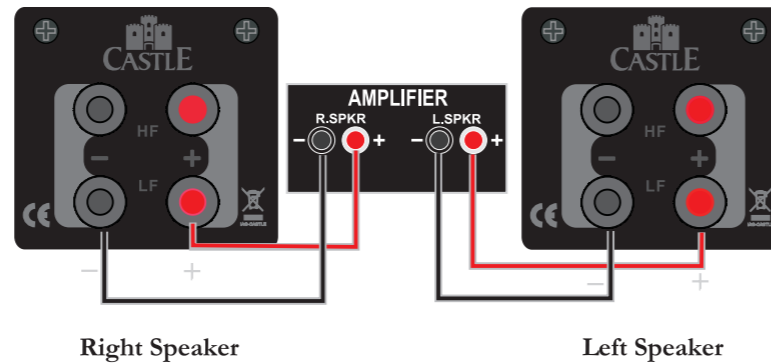

Right Speaker

Left Speaker

Bi-Wiring

To Bi-wire, you will need to install two lengths of twin core cable between the amplifier and each loudspeaker.

Note: Some amplifiers have two pairs of output terminals to facilitate bi-wiring but this is not essential. The advantages of bi-wiring are fully retained if your amplifier has only one pair of loudspeaker terminals per channel (as in the illustration).

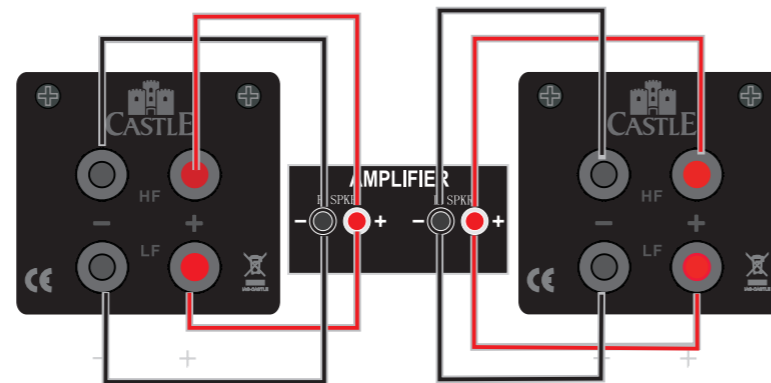

Right Speaker

Left Speaker

Bi-Amping

Two amplifiers are used. One amplifier is connected to the treble terminals the other to the bass terminals.

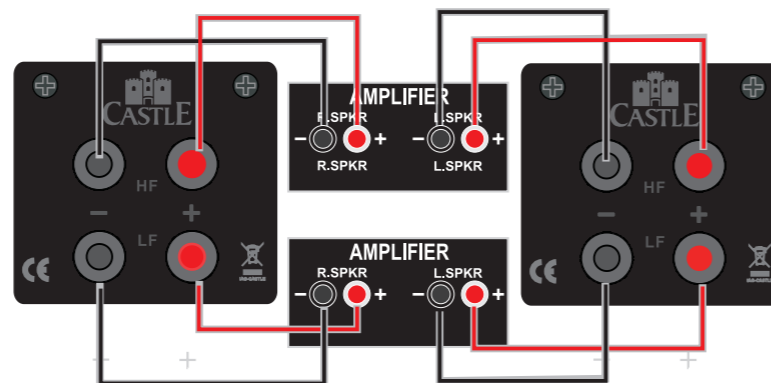

Right Speaker

Left Speaker

Phase

It is essential that you strictly observe the colour code when connecting your loudspeakers. Incorrectly connected (out of phase) loudspeakers suffer from poor bass response and fuzzy imaging. Phase anomalies in high fidelity systems can be extremely annoying and, especially when the speakers are bi-wired or bi-amped, difficult to pin down. A correctly connected Castle loudspeaker system will give you deep sonorous bass with pinpoint imaging and clarity.

Positioning Stereo Loudspeakers

The distance between the speakers should be the same as between you and the speakers.

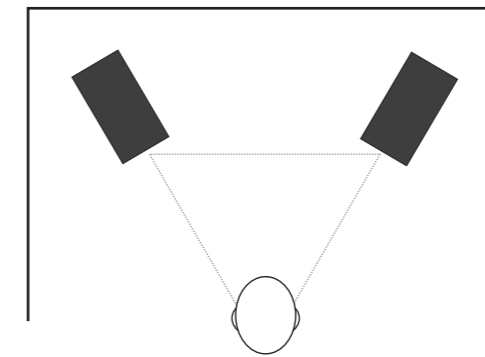

If the loudspeakers are placed too close to the walls, the bass will increase but may be boomy and indistinct. If the loudspeakers are placed further away from the walls, the inward angle ("toe in") may be increased by up to 30%. As personal taste plays a large role, experiment with different configurations and play a wide range of programme material before finalising the position of your speakers.

The optimum listening position is in the area broadly known as the 'sweet spot'. The more extreme the angle, the narrower is the sweet spot. Castle loudspeakers are designed to cover a medium sonic perspective so there should be no need for extreme settings.

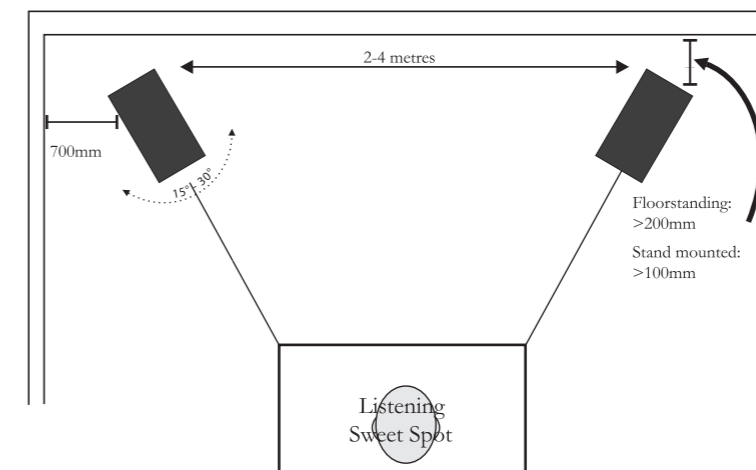

Stand Mounting Loudspeakers

The Avon 1 and Avon 2 are designed for stand mounting. The stands should be sturdy and offer optimum support for the loudspeaker. As an alternative the speakers may be wall mounted on rigid brackets or placed on rigid shelves.

Ideally the tweeter should be at ear level to a seated listener. If the rear panels of the speakers are placed close to the walls, the amount of bass will be increased but the clarity may well suffer - you should experiment until you get the best result.